

(19) World Intellectual Property  
Organization  
International Bureau



(43) International Publication Date  
12 February 2004 (12.02.2004)

PCT

(10) International Publication Number  
WO 2004/012602 A2

- (51) International Patent Classification<sup>7</sup>: A61B 17/00
- (21) International Application Number:  
PCT/EP2003/008246
- (22) International Filing Date: 25 July 2003 (25.07.2003)
- (25) Filing Language: English
- (26) Publication Language: English
- (30) Priority Data:  
60/401,226 1 August 2002 (01.08.2002) US
- (71) Applicant (for all designated States except US): ABBOTT LABORATORIES VASCULAR ENTERPRISES, LIMITED [IE/IE]; Earlsfort Center, Terrace, Dublin 2 (IE).
- (72) Inventor; and
- (75) Inventor/Applicant (for US only): MICHLITSCH, Kenneth, J. [US/US]; 4613 Pamela Commons, Livermore, CA 94550 (US).
- (74) Agent: VOSSIUS & PARTNER; Siebertstrasse 4, 81675, Munich (DE).
- (81) Designated States (national): AE, AG, AL, AM, AT, AU, AZ, BA, BB, BG, BR, BY, BZ, CA, CH, CN, CO, CR, CU, CZ, DE, DK, DM, DZ, EC, EE, ES, FI, GB, GD, GE, GH, GM, HR, HU, ID, IL, IN, IS, JP, KE, KG, KP, KR, KZ, LC, LK, LR, LS, LT, LU, LV, MA, MD, MG, MK, MN, MW, MX, MZ, NI, NO, NZ, OM, PG, PH, PL, PT, RO, RU, SC, SD, SE, SG, SK, SL, SY, TJ, TM, TN, TR, TT, TZ, UA, UG, US, UZ, VC, VN, YU, ZA, ZM, ZW.
- (84) Designated States (regional): ARIPO patent (GH, GM, KE, LS, MW, MZ, SD, SL, SZ, TZ, UG, ZM, ZW), Eurasian patent (AM, AZ, BY, KG, KZ, MD, RU, TJ, TM), European patent (AT, BE, BG, CH, CY, CZ, DE, DK, EE, ES, FI, FR, GB, GR, HU, IE, IT, LU, MC, NL, PT, RO, SE, SI, SK, TR), OAPI patent (BF, BJ, CF, CG, CI, CM, GA, GN, GQ, GW, ML, MR, NE, SN, TD, TG).
- Published:**  
— without international search report and to be republished upon receipt of that report
- For two-letter codes and other abbreviations, refer to the "Guidance Notes on Codes and Abbreviations" appearing at the beginning of each regular issue of the PCT Gazette.*

(54) Title: AUTOLOGOUS WOUND SEALING APPARATUS

(57) Abstract: Apparatus is provided for sealing a vascular puncture tract by forming the autologous plug within the puncture tract, and extruding that plug into the puncture tract. The apparatus of the present invention forms an autologous blood plug by drawing blood into the apparatus from a vessel, mixing a blood congealing agent with the drawn blood, and ejecting a plug formed from the clotted blood within the puncture tract. Also provided are various closure elements to isolate the drawn blood from the vessel during mixture with the blood congealing agent, and to facilitate placement of the apparatus relative to the vessel.

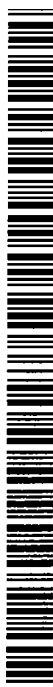

WO 2004/012602 A2

tissue rebuilding have sealed the puncture). This method, however, presents numerous problems. In some instances, this pressure must be applied for up to an hour or more, during which time the patient is  
5 uncomfortably immobilized. In addition, there exists a risk of hematoma since bleeding from the puncture may continue until sufficient clotting occurs, particularly if the patient moves during the clotting process. Furthermore, application of external pressure to stop  
10 bleeding may be unsuitable for patients with substantial amounts of subcutaneous adipose tissue since the skin surface may be a considerable distance from the puncture site, thereby rendering external compression less effective.

15 **[0004]** Another traditional approach to subcutaneous puncture closure comprises having a medical practitioner internally suture the vessel puncture. This method, however, often requires a complex procedure and requires considerable skill by the  
20 medical practitioner.

**[0005]** Mechanical occlusion devices have been proposed for sealing, e.g., atrial septal defects, and typically comprise two expandable disks that sealingly compress tissue surrounding the hole. One such device  
25 is described in U.S. Patent No. 5,425,744 to Fagan et al. A significant drawback to the Fagan device is that, when deployed into a vessel, the device may protrude into the blood stream, thereby disturbing blood flow and causing thrombosis in the vessel.

30 **[0006]** Apparatus and methods also are known in which a plug is introduced into the vessel puncture, to cover the puncture and promote hemostasis. Various types of plugs have been proposed. One example is described in

prevent leakage of blood congealing agents into a vessel during delivery thereof.

Summary of the Invention

5 [0012] In view of the foregoing, it is an object of the present invention to provide apparatus for sealing a puncture tract by forming and extruding an autologous plug within the puncture tract.

[0013] It also is an object of the present invention  
10 to provide apparatus for sealing a puncture tract that are easy to use, and decrease opportunities for error and contamination.

[0014] It further is an object of the present invention to provide apparatus for sealing a puncture  
15 tract that facilitate placement of the apparatus relative to a vessel.

[0015] It even further is an object of the present invention to provide apparatus for sealing a puncture tract that prevent leakage of blood congealing agents  
20 into a vessel during delivery thereof.

[0016] These and other objects of the present invention are accomplished by providing apparatus for sealing a puncture tract by forming and extruding an autologous plug within the puncture tract. More  
25 specifically, the apparatus of the present invention forms the autologous plug by drawing blood into the apparatus from a vessel in fluid communication with the puncture tract, and supplying a blood congealing agent to the drawn blood. Consequently, a plug of clotted  
30 blood forms within the apparatus, which then may be extruded out of the apparatus and disposed along at least a portion of the length of the puncture tract.

surrounding the puncture tract compressively engages the autologous plug along its length, generating frictional forces that prevent the plug from becoming dislodged into the vessel.

5

Brief Description of the Drawings

[0021] Further features of the present invention, its nature and various advantages will be more apparent from the accompanying drawings and the following  
10 detailed description of the preferred embodiments, in which:

[0022] FIG. 1 is a schematic side-sectional view of a vascular puncture tract;

[0023] FIG. 2 is a schematic perspective view of  
15 apparatus of the present invention;

[0024] FIG. 3 is a schematic side-sectional view of the apparatus of FIG. 2;

[0025] FIGS. 4A-4E are schematic side-sectional views describing an exemplary method of using the  
20 apparatus of FIGS. 2 and 3;

[0026] FIGS. 5A-5E are schematic side-sectional and end views of alternative embodiments of apparatus of the present invention;

[0027] FIG. 6 is a schematic side-sectional view of  
25 another alternative embodiment of the apparatus of the present invention;

[0028] FIGS. 7A and 7B are, respectively, a schematic exploded perspective view and a schematic side-sectional view of an iris closure of the apparatus  
30 of FIG. 6;

[0029] FIGS. 8 are schematic plane views of an inner tube and the iris closure, respectively, of the apparatus of FIGS. 6 and 7;

autologous plug is extruded from the lumen to seal puncture tract **TR**, thereby sealing vessel **V** from blood leakage.

[0036] An illustrative embodiment of device 10 of the present invention is shown in FIGS. 2 and 3. Device 10 comprises housing 12 having manifold 14, injection port 16, and distal opening 18, plunger 20 having head 21 and shank 23 disposed for axial translation within housing 12, and pledget 22. Pledget 22 may be disposed within and is removably coupled to housing 12. As described in greater detail hereinbelow, fluid communication between distal opening 18 and injection port 16 permits a medical practitioner to easily determine when device 10 has been advanced within puncture tract **TR** to a position just proximal to vessel **V**.

[0037] Housing 12 further comprises inner tube 24 and outer tube 28, which may be distally tapered to provide an atraumatic bumper for advancement of device 10 through puncture tract **TR**, or may be distally angled for flush alignment with an angled puncture tract **TR**, such as the puncture tract of FIG. 1. Inner and outer tubes 24 and 28 form annular lumen 30, which is in fluid communication with manifold 14 and injection port 16. Annular lumen 30 extends along the length of inner tube 24 and is in fluid communication with central lumen 26, via plurality of apertures 32. Apertures 32 are disposed through and along the axial length of inner tube 24. Optional gap 34 is defined between the distal ends of inner and outer tubes 24 and 28.

[0038] Fluid communication between injection port 16 and central lumen 26 permits a blood congealing agent to be injected through injection port 16, e.g., a luer

[0041] In a preferred embodiment, disk 42 is elliptically shaped, and has major and minor axes that permit disk 42 to completely cover puncture P when disposed therein. Accordingly, when pledget 22 is engaged to the inner wall of vessel V within puncture P, immediate hemostasis may be achieved. If the minor axis of disk 42 is greater than the diameter of central lumen 26, disk 42 may be made of a material that permits disk 42 to be elastically deformed to fit within central lumen 26 during delivery of the pledget to vessel V. Once ejected from central lumen 26, disk 42 elastically recovers its elliptical shape. Of course, in addition to elliptical shapes, it will be evident to one of ordinary skill in the art that disk 42 may comprise other shapes, e.g., circular or oblong, so long as disk 42 can completely occlude puncture P when disposed therein.

[0042] In accordance with one aspect of the present invention, pledget 22 and thread 38 are made of biodegradable materials, e.g., polyglycolic acid. This permits pledget 22 and thread 38 to be resorbed and excreted from the body along with resorption of the autologous plug, after puncture P and tract TR have healed. It will be evident to one of ordinary skill in the art that, by controlling parameters such as the degree of polymerization and crystallization, the biodegradable material may be engineered to comprise properties that permit disk 42 to elastically deform when inserted into central lumen 26 during delivery, and to degrade at a predetermined rate.

[0043] Referring now to FIGS. 4, an exemplary method of using device 10 of the present invention is described. Housing 12 of device 10 optionally may

manifold 14 when pledget 22 has been completely advanced into vessel V. Because disk 42 of pledget 22 is elliptical, disk 42 will tend to align itself with its major axis parallel to the flow of blood, as shown in FIG. 4B.

[0046] Thereafter, plunger 20 is actuated in the proximal direction to draw blood B from vessel V into central lumen 26. Due to the presence of apertures 32 and gap 34, blood also may be drawn into annular lumen 30 and/or manifold 14. Any air within device 10 may escape therefrom through an air vent (not shown), and/or injection port 16.

[0047] Once central lumen 26 is filled with blood, a proximal force is applied to the proximal ends of thread 38 disposed outside of puncture tract TR to engage pledget 22 against the inner wall of vessel V, thereby sealing the puncture tract from the vessel and providing immediate hemostasis. Thereafter, source S of a blood congealing agent, such as thrombin, fibrin and/or human factor VIII, is coupled to injection port 16, and blood congealing agent A is injected into manifold 14. From manifold 14, agent A is introduced into blood present in annular lumen 30, and into central lumen 26 via apertures 32 and gap 34, where it initiates clotting of the blood therein. Due to the engagement of pledget 22 against the inner wall of vessel V, the blood congealing agent will not leak into vessel V.

[0048] After a period of time, the blood within central lumen 26 solidifies into autologous plug PL, with thread 38 embedded therein. In a preferred embodiment, autologous plug PL comprises a substantially cylindrical rod. Autologous plug PL then

lumen 50. If outer tube 48 is transparent, visual confirmation may be made. Air within annular lumen 50 may be evacuated through an air vent (not shown) in fluid communication with annular lumen 50.

5 [0052] The blood coagulating agent of device 44 includes matrix 60 that is preferably biodegradable. Matrix 60 may comprise, for example, a gauze, a biologically compatible foam, and/or a spun fiber, such as a mass of a loosely spun fiber, e.g. polyglycolic  
10 acid. Matrix 60 promotes coagulation of blood upon contact and mixture therewith and optionally may be coated with, e.g., thrombin, fibrin and/or human factor VIII. Matrix 60 may comprise optional inner lumen 62 for disposition of thread 38 of pledget 22 through the  
15 matrix.

[0053] During delivery of device 44 into puncture tract **TR**, matrix 60 is disposed within central lumen 52 between plunger 20 and pledget 22. Once backbleed of blood into annular lumen 50 confirms that device 44 is  
20 positioned just proximal of vessel **V**, plunger 20 may be distally translated to advance pledget 22 into vessel **V**. This position, which may be indicated by a marker (not shown) on shaft 23 of plunger 20, corresponds to placement of matrix 60 just proximal of gap 56.

25 [0054] Thereafter, plunger 20 is proximally retracted to draw blood into device 44. Blood enters through opening 58 and saturates matrix 60 as it flows therethrough into the proximal portion of central lumen 52. Blood also may be drawn into annular lumen 50 via  
30 gap 56, and introduced into central lumen 52 via apertures 54, if present. Apertures 54 preferably are disposed along the length of inner tube 46, such that blood may evenly distribute along the length of central



be pre-coated with a blood congealing agent, e.g., thrombin, fibrin and/or human factor VIII, or lined with a matrix that is preferably biodegradable (e.g., gauze or biologically compatible foam). This  
5 eliminates the need to separately introduce a fluid blood congealing agent into the blood isolated within central lumen 52, thereby eliminating the need for injection lumen 76 in plunger 66. Coagulation of blood further may be enhanced by contact with platinum wires  
10 78, or convection and conduction of heat from thermo-resistive wires 78 disposed within inner tube 68, as shown in the inset of FIG. 5B. If thermo-resistive wires are provided, they may be proximally connected to a power source (not shown).

15 [0057] In a still further alternative embodiment of device 64, outer tube 48 may be omitted, thereby eliminating annular lumen 50, as well as gap 56. Shown in FIG. 5C, device 80 may be provided with only a single inner tube 68 having central lumen 52 in which  
20 shank 74 of plunger 66 may be translatably disposed. In this embodiment, central lumen 52 or injection lumen 76 of plunger 66 also may serve as a backbleed lumen through which blood may pass for visual confirmation of proper placement of device 80 proximate to vessel V.  
25 As discussed previously, injection lumen 76 further may be used as a thread lumen for disposition of thread 38 therethrough.

[0058] As with device 64, blood congealing agent may be introduced to the blood drawn into central lumen 52  
30 by injection of the blood congealing agent into injection lumen 76, pre-coating or lining the central lumen with the blood congealing agent, e.g., thrombin, fibrin and/or human factor VIII, or exposing the blood

[0061] It will be evident to one of ordinary skill in the art that, while FIG. 5D illustrates a plurality of channels disposed along the circumference of matrix 82, channels 84 also may include other configurations, such as lumens 86 disposed through the longitudinal length of the matrix, as shown in FIG. 5E, or a combination thereof.

[0062] Referring now to FIG. 6, a still further alternative embodiment of the present invention is described. Like the embodiment of FIGS. 2 and 3, device 90 comprises housing 92 having manifold 94 and injection port 96, and plunger 98 having head 100 and shank 102 disposed for axial translation within housing 92. Housing 92 includes inner tube 104 and outer tube 106, wherein inner tube 104 is rotatable but not axially translatable relative to outer tube 106. Rotation of inner tube 104 may be facilitated by actuator 107 coupled thereto. Annular lumen 108 is formed between inner and outer tubes 104 and 106, and is in fluid communication with manifold 94 and injection port 96. Annular lumen 108 is in fluid communication with central lumen 110 via plurality of apertures 112, which is disposed through and along the axial length of inner tube 104. Gap 114 is defined between the distal ends of inner and outer tubes 104 and 106.

[0063] As in device 10, the diameter of central lumen 110 is designed to form an autologous plug therein, that engages tissue **T** when extruded into puncture tract **TR**. Shank 102 is slightly smaller than that of central lumen 110 and may be translated therein.

iris blades 126 therewith, thereby exposing or sealing opening 124 depending on the direction of rotation of iris plate 120 relative to slots 132, or vice versa.

[0066] In operation, to expose opening 124 from its  
5 sealed configuration shown in FIGS. 7B and 8B, inner tube 104 is rotated, e.g., in the counter-clockwise direction relative to outer tube 106. This causes slots 132 engaged to proximal bearings 130 to impart a tangential force to each bearing 130. Since proximal  
10 bearings 130 are rigidly affixed to iris blades 126, the tangential forces imparted to bearings 130 force movement of iris blades 126 and distal bearings 128 along the curve of iris tracks 122. As illustrated in FIG. 8C, as distal bearings 128 travel therealong, iris  
15 blades 126 rotate with the curve of iris tracks 132, retracting the blades and exposing opening 124. Contemporaneously, proximal bearings 130 move along slots 132 in the outwardly radial direction. Rotation of inner tube 104 relative to outer tube 106 terminates  
20 when distal bearings 128 contact outer ends 134 of iris tracks 122. At this point, iris blades 126 have been completely retracted to expose opening 124.

[0067] To seal opening 124, inner tube 104 is rotated, e.g., in the clockwise direction relative to  
25 outer tube 106. This forces distal bearings 128 to move along the curve of iris tracks 122 in the inwardly radial direction towards opening 124, rotating iris blades 126 therewith to seal opening 124. When distal bearings 128 contact inner ends 136 of iris tracks 122,  
30 iris blades 126 have fully sealed opening 124.

[0068] While iris blades 126 are shown disposed proximal to iris plate 120 in FIGS. 6 and 7, it will be evident to one of ordinary skill in the art that iris

[0071] Once device 90 is properly positioned just proximal to vessel V, plunger 98 is actuated in the proximal direction to draw blood B from vessel V into central lumen 110, as seen in FIG. 9C. Due to the presence of apertures 112 and gap 114, blood also may be drawn into annular lumen 108 and/or manifold 94. Any air within device 90 may be expelled therefrom through an air vent (not shown) and/or injection port 96.

10 [0072] Once central lumen 110 is filled with blood B, actuator 107 may be used to rotate inner tube 104 relative to outer tube 106, actuating iris blades 126 to seal opening 124 in the manner discussed above.

[0073] Source S of blood congealing agent is coupled to injection port 96, and blood congealing agent A is injected into manifold 94. From manifold 94, blood congealing agent A mixes with blood present in annular lumen 108 and into central lumen 110, via apertures 112 and gap 114, initiating clotting of the blood. Since opening 124 is sealed, thereby isolating the blood within device 90, blood congealing agent A will not leak into vessel V. After a period of time, the blood within lumen 110 solidifies into autologous plug PL. Accordingly, in a preferred embodiment, autologous plug PL comprises a cylindrical rod.

[0074] Inner tube 104 then is rotated relative to outer tube 106 to expose opening 124 in the manner discussed above. Autologous plug PL is extruded from central lumen 110 by holding plunger 98 stationary as housing 92 is proximally retracted so that plunger 98 urges autologous plug PL out of lumen 110, as seen in FIG. 9D. Any blood contiguously coagulated with autologous plug PL, such as that potentially disposed

among opening 150, annular lumen 158 and central lumen 162 of inner tube 154.

[0077] Preferably, outer tube 156 is made from a transparent polymer to facilitate visual confirmation of the advancement of device 140 to a position just proximal to vessel V in puncture tract TR. In use, when opening 150 is disposed just proximal to vessel V, blood backbleeds through opening 150 and gap 160 into annular lumen 158. Air within annular lumen 158 may be evacuated through an air vent (not shown) in fluid communication therewith.

[0078] Device 140 also comprises plunger 164 and flange 166 that facilitates insertion of housing 152 within puncture tract TR. In the present embodiment, plunger 164 comprises injection port 168 disposed at the proximal end, shank 170 that is configured to be translatably disposed within central lumen 162, and injection lumen 172 disposed therethrough. Injection port 168 may comprise a coupling, such as a luer valve, that can be releasably joined to a source of blood congealing agent (not shown). Accordingly, instead of injecting blood congealing agent into a manifold as in the preceding embodiment, device 140 permits injection directly into plunger 164, thereby eliminating apertures 112 from device 90 and reserving annular lumen 158 solely to provide visual confirmation of the disposition of device 140 just proximal to vessel V.

[0079] In an alternative embodiment of device 140, inner wall 174 may be pre-coated with a blood congealing agent, e.g., thrombin, fibrin and/or human factor VIII, or lined with a matrix (e.g., gauze, spun fiber or biologically compatible foam). This eliminates the need to introduce a blood congealing

[0082] Referring now to FIG. 11, another embodiment of the apparatus of the present invention is described. Device 180 is similar to devices 90 and 140 respectively of FIGS. 6-8 and 10, except that the iris closures of those embodiments are replaced by alignment closure 182. Affixed to the distal end of inner tube 184 is proximal plate 186 having through-wall slots 188. Affixed to the distal end of outer tube 190 is distal plate 192 having through-wall slots 194 that have a shape identical to that of slots 188. When slots 188 and 194 are aligned, as shown in FIGS. 11 and 12A, blood may be drawn into central lumen 196 disposed through the length of inner tube 184, or an autologous plug may be extruded therethrough. When inner tube 184 is rotated relative to outer tube 190, distal and proximal plates 192 and 186 respectively obscure slots 188 and 194, as shown in FIG. 12B. In this configuration, blood is isolated within central lumen 196, and blood congealing agent may be supplied to the isolated blood to initiate clotting thereof.

[0083] Optional annular lumen 198 is defined by inner and outer tubes 184 and 190, and is in fluid communication with central lumen 196 via optional apertures 200 circumferentially disposed through inner tube 184 just proximal to proximal plate 186. To determine if device 180 has been properly positioned just proximal to vessel V, blood may backbleed through aligned slots 188 and 194 and apertures 200 into annular lumen 198. Accordingly, during delivery of device 180 into a puncture tract, the maximum distal position to which plunger 202 may be advanced within central lumen 196 is a position just proximal to apertures 200. This position may be indicated by a

190 to align slots 188 and 194. Plunger 202 is held stationary as device 180 is proximally retracted from puncture tract **TR**, thereby urging autologous plug **PL** from central lumen 196 through slots 188 and 194. Once  
5 disposed within puncture tract **TR**, the segments of the autologous plug that had been extruded through slots 188 and 194 are urged together due to the compressive pressure of tissue **T** surrounding the puncture tract. In this manner, puncture tract **TR** is sealed from  
10 leakage of blood.

[0085] Referring now to FIGS. 13, yet another alternative embodiment of the present invention is described. Device 210 includes housing 212 having inner and outer tubes 214 and 216, which form annular  
15 lumen 218 therebetween. Device 210 also includes plunger 220 translatably disposed within central lumen 222, and membrane 224, which is preferably biodegradable. Membrane 224 is disposed over distal opening 226 of central lumen 222 and is releasably  
20 attached to inner wall 228 of inner tube 214 so that membrane 224 forms a sock within which is disposed blood congealing agent 230. Membrane 224 is preferably attached to inner wall 228 with a biodegradable  
25 adhesive or suture that permits the membrane to be sheared from inner wall 228 when an axial force is applied to blood congealing agent 230.

[0086] Membrane 224 is permeable to blood but impermeable to blood congealing agent 230, thereby  
30 permitting blood to be introduced into central lumen 222 and yet isolating the mixture of blood and blood congealing agent from vessel **V**. Selective permeability may be achieved, for example, by incorporating pores of a predetermined size within membrane 224. Thus, for

agent 230. Device 210 is distally translated along the puncture tract until backbleeding, e.g. through annular lumen 218, indicates that the device is properly positioned just proximal to vessel **V**. Plunger 220 then  
5 is actuated in the proximal direction to draw blood into central lumen 222 through membrane 224, covering distal opening 226, as well as apertures 232, if present. Contact and mixture with blood congealing agent 230 coagulates the blood into an autologous plug,  
10 integrating blood congealing agent 230 and membrane 224 therein. When plunger 220 is translated in the distal direction to extrude the formed autologous plug from central lumen 222, the distal force transmitted to the adhesive or suture binding membrane 224 to inner wall  
15 228 shears membrane 224 therefrom. Disposed within puncture tract **TR**, the autologous plug engages tissue **T** surrounding the puncture tract to prevent blood leakage from vessel **V**.

[0090] In an alternative embodiment of device 210,  
20 outer tube 216 and apertures 232 may be omitted, thereby eliminating annular lumen 218. For backbleed indication to facilitate visual confirmation of the placement of the present device just proximal to vessel **V**, plunger 220 may be provided with an injection lumen  
25 like that described with respect to FIGS. 5B-5C and 10A-10B.

[0091] While preferred illustrative embodiments of the invention are described above, it will be apparent to one skilled in the art that various changes and  
30 modifications may be made therein without departing from the invention. For example, shorter autologous plugs may be formed that only cover a portion of the length of the puncture tract. Furthermore, various



Claims

1. A device for sealing a puncture tract by forming and extruding an autologous plug within the puncture tract, wherein the puncture tract is disposed within tissue proximal to a vessel, the device comprising:

a housing having a lumen adapted to mix a volume of blood with a blood congealing agent;

a closure element configured to be inserted into the puncture tract and to isolate the mixture of the volume of blood and the blood congealing agent from the vessel during formation of the autologous plug from the volume of blood by action of the blood congealing agent; and

a plunger disposed for translation within the lumen to extrude the autologous plug formed within the lumen.

2. The device of claim 1, wherein the housing comprises a second lumen to facilitate placement of a distal end of the device.

3. The device of claim 2, wherein the second lumen is disposed within the plunger.

4. The device of claim 1, 2 or 3, wherein the autologous plug formed in the lumen has a length and a form factor that causes the autologous plug to engage tissue surrounding the puncture tract after ejection by the plunger into the puncture tract.

5. The device of claim 1, 2, 3 or 4, wherein the closure element comprises a pledget and thread.

the lumen subsequent to actuation of the closure element.

14. The device of claim 11, 12 or 13, wherein the blood congealing agent comprises a platinum wire.

15. The device of claim 11, 12, 13 or 14, wherein the blood congealing agent comprises a thermo-resistive wire.

16. The device of any one of claims 1 to 15, wherein the blood congealing agent is chosen from the group consisting of thrombin, fibrin, human factor VIII, and combinations thereof.

17. The device of any one of claims 1 to 16, wherein the blood congealing agent comprises a matrix.

18. The device of claim 17, wherein the matrix is chosen from the group consisting of gauze, biocompatible foam, and spun fiber.

19. The device of claim 17 or 18, wherein the matrix is biodegradable.

20. The device of claim 17, 18 or 19, wherein the matrix comprises at least one channel disposed therethrough.

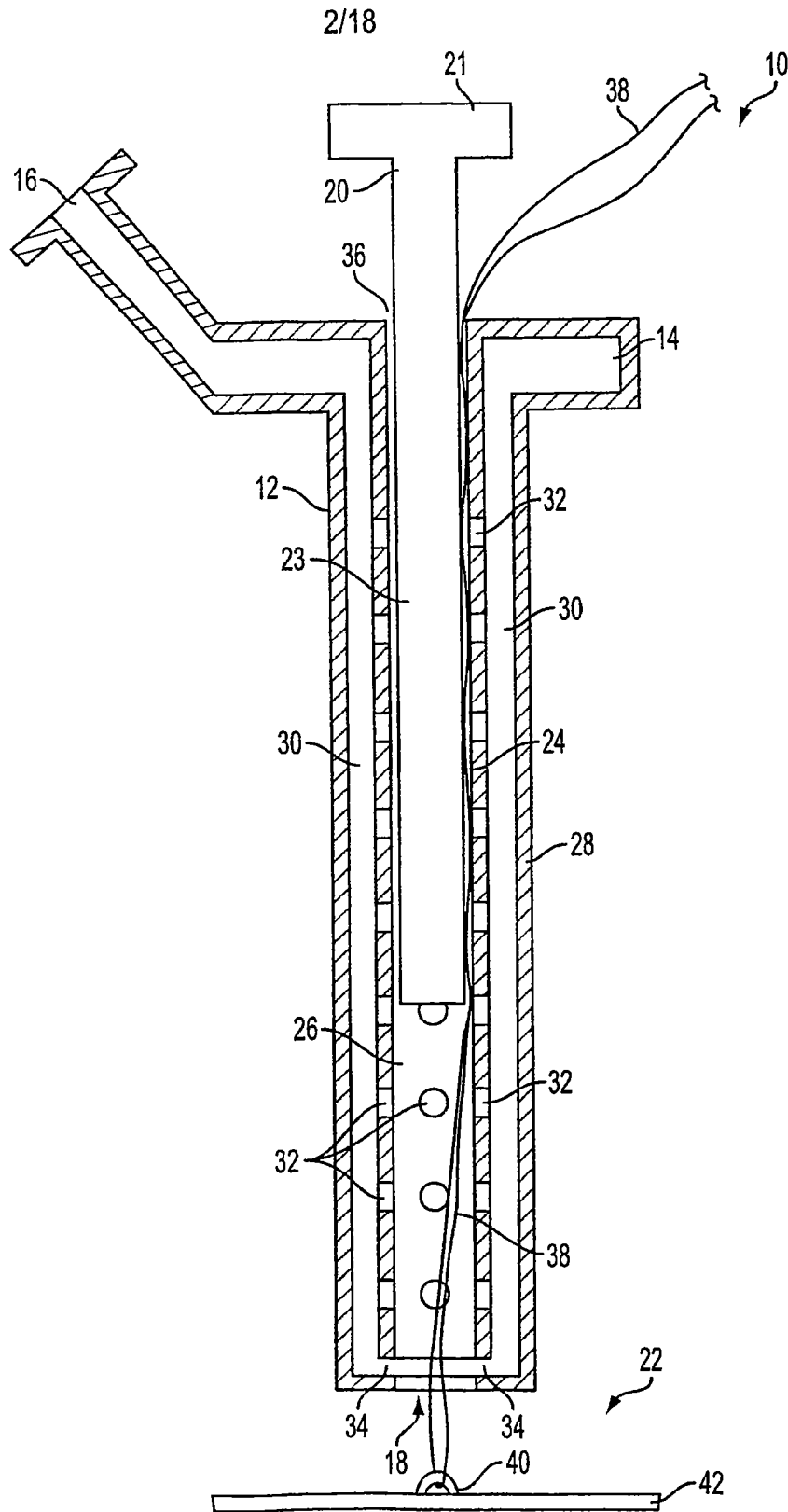

FIG. 3

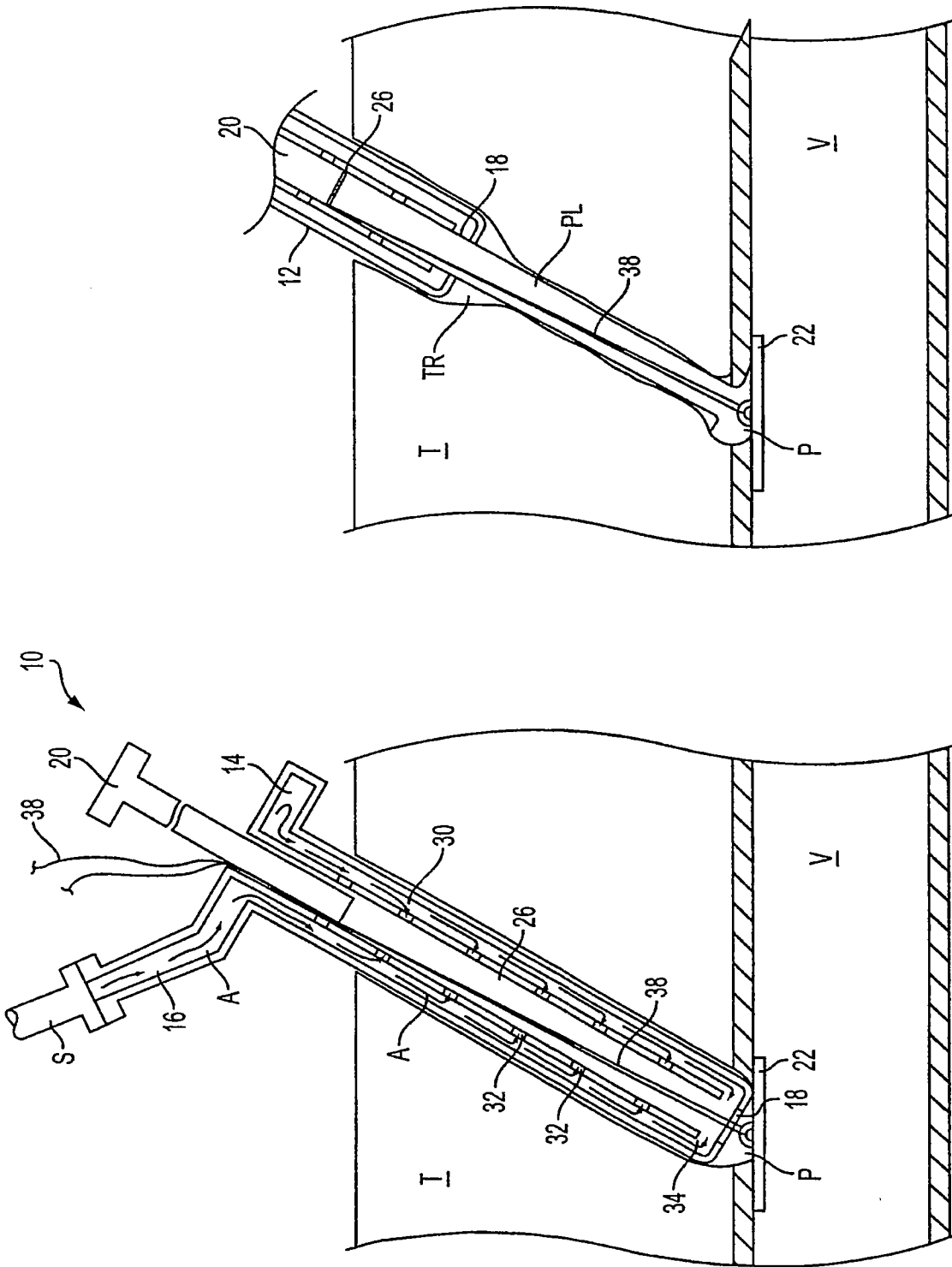

FIG. 4D

FIG. 4C

6/18

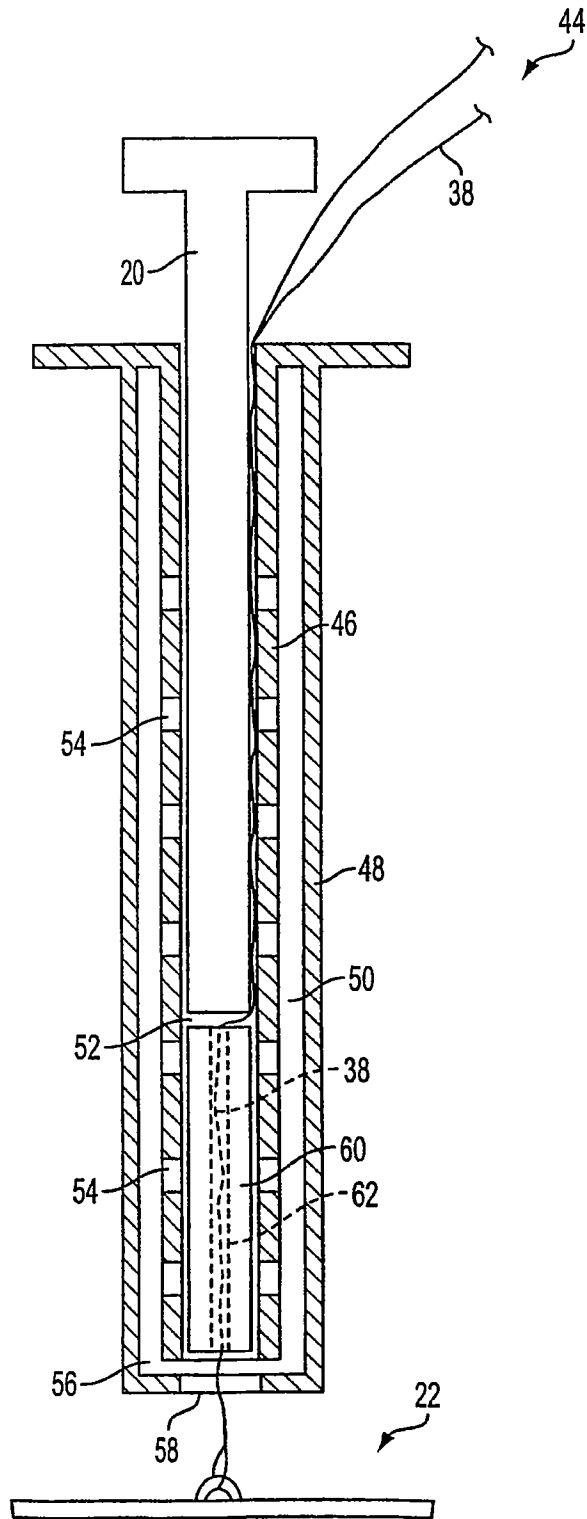
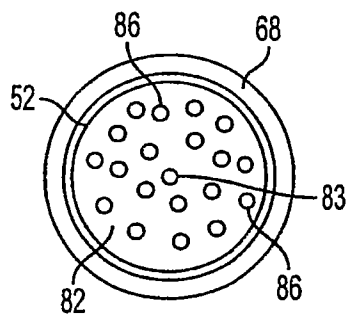
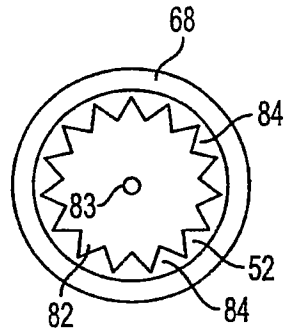
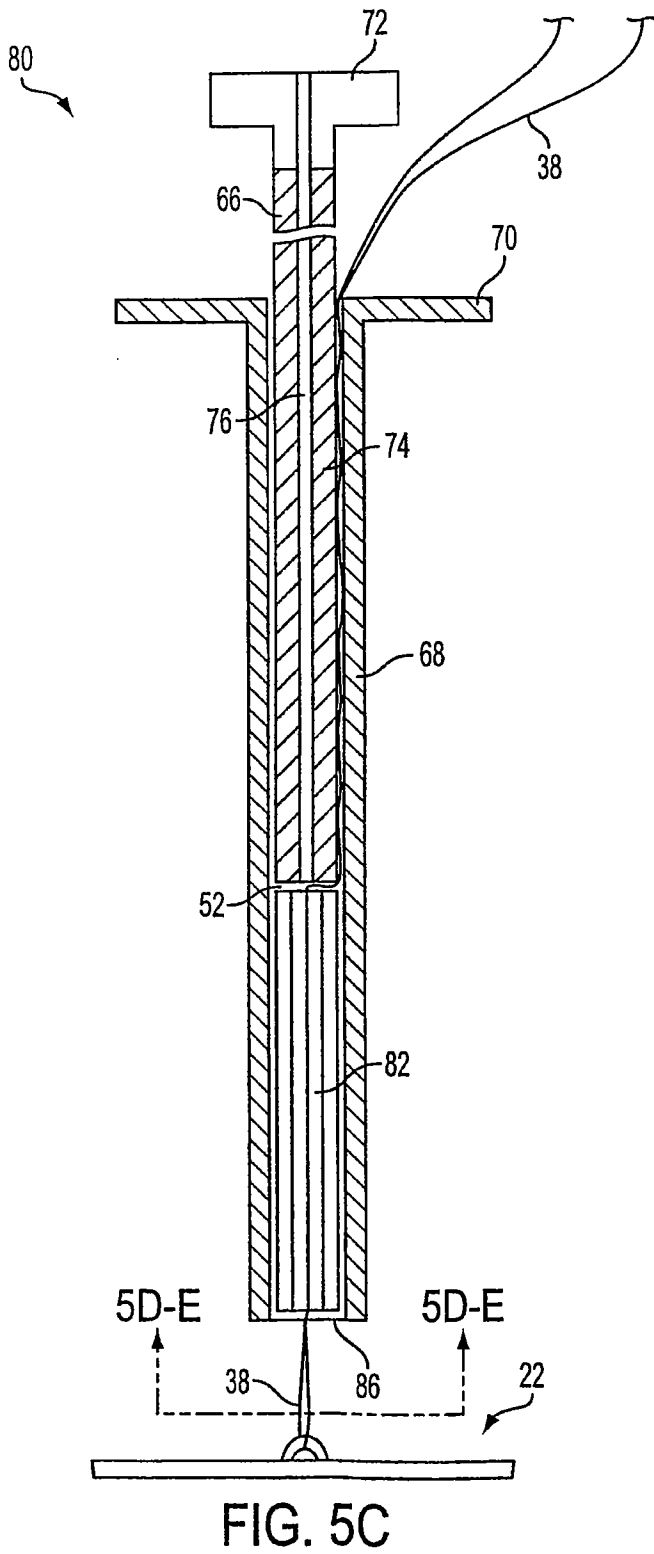
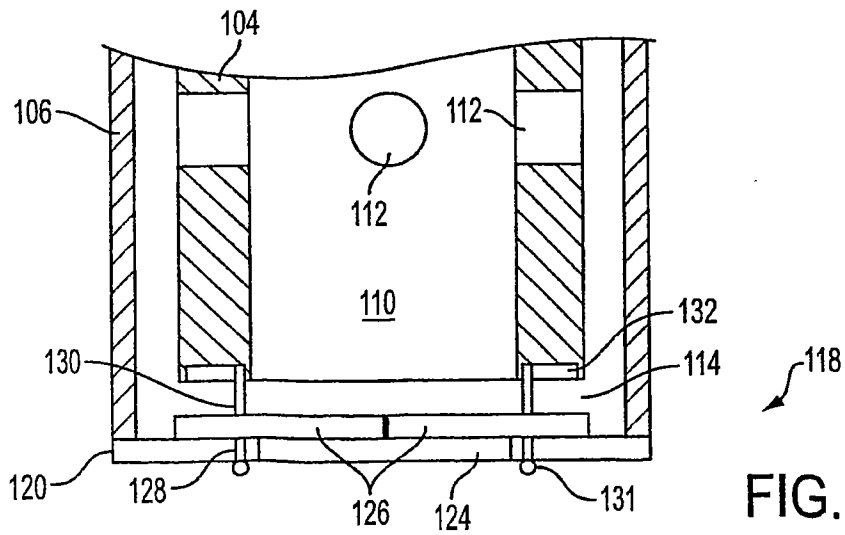
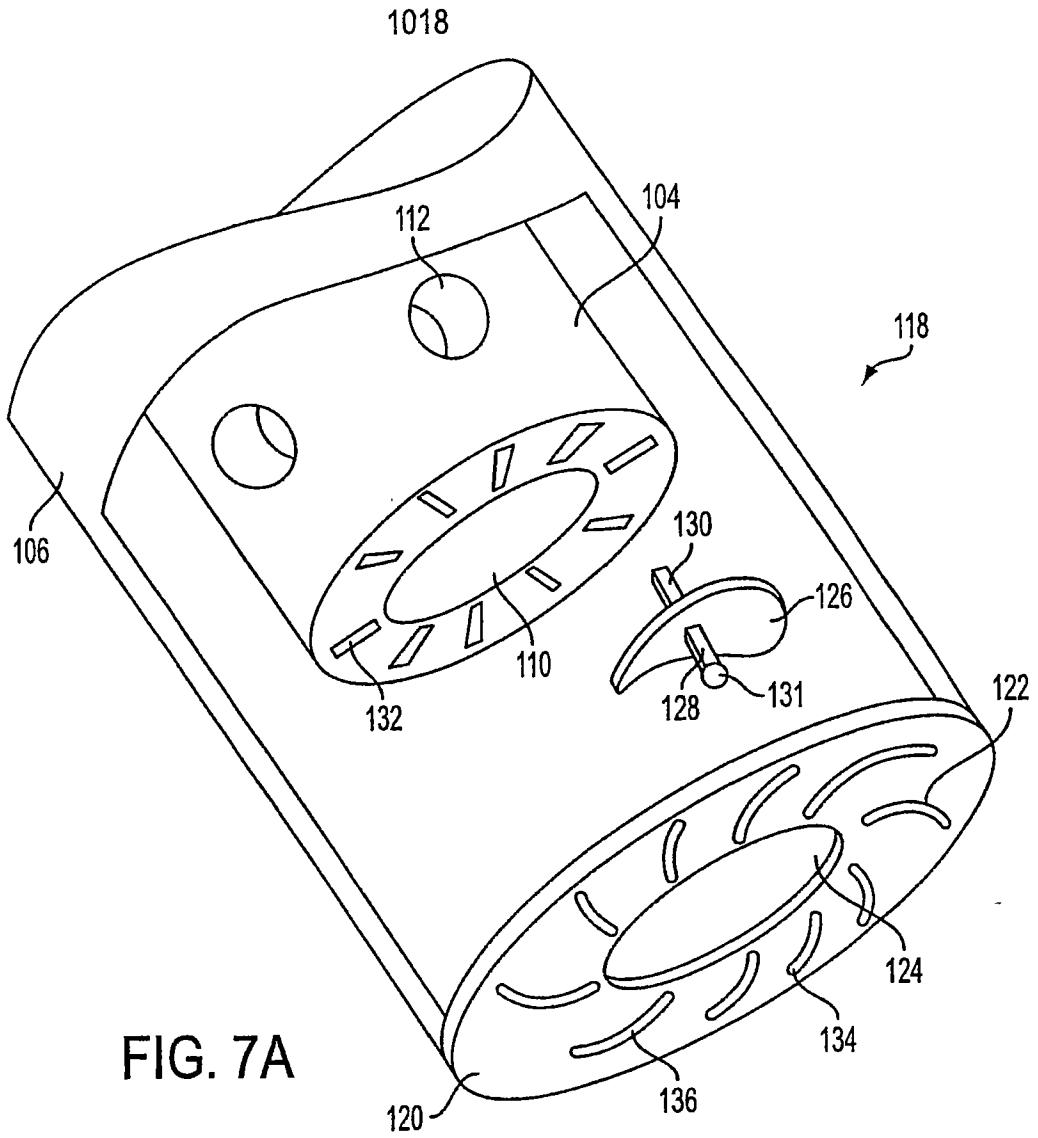

FIG. 5A





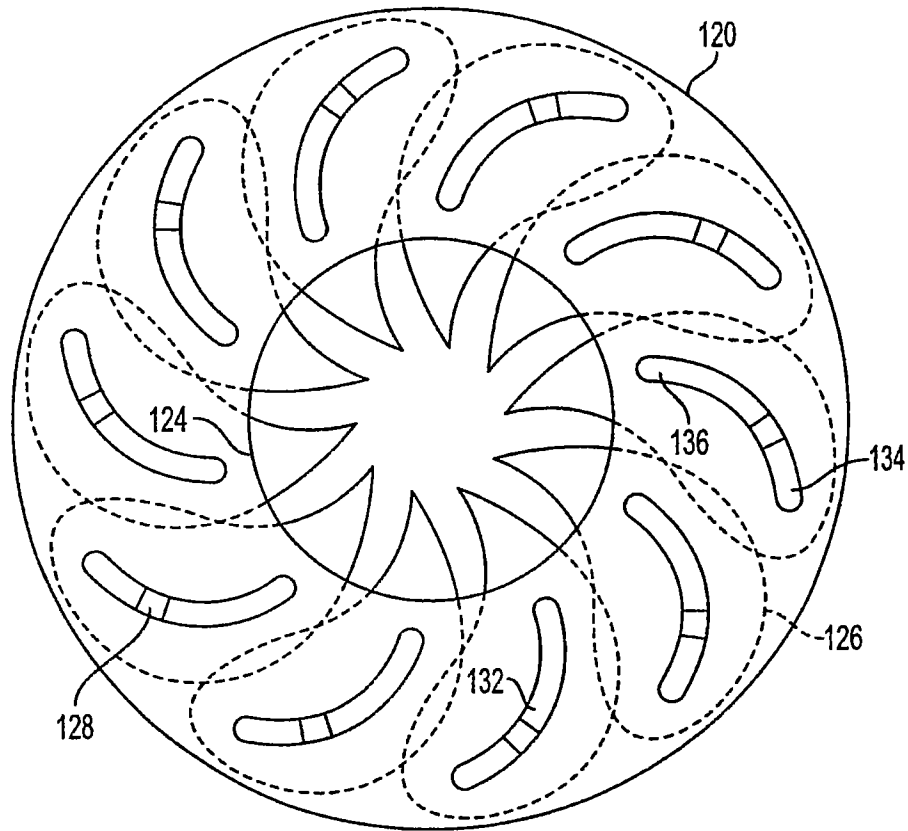

FIG. 8C



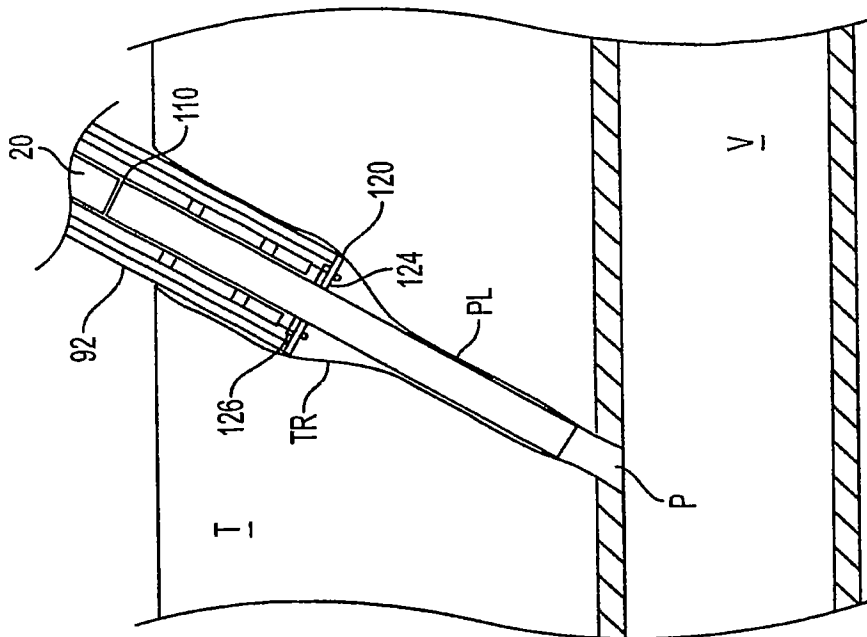

FIG. 9D

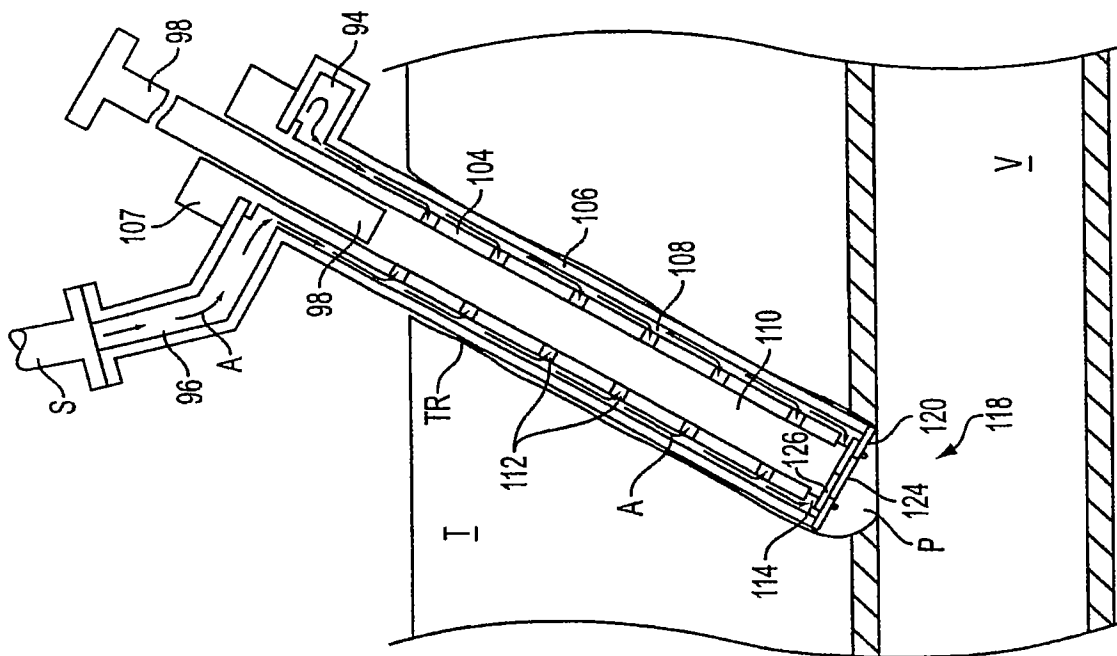

FIG. 9C

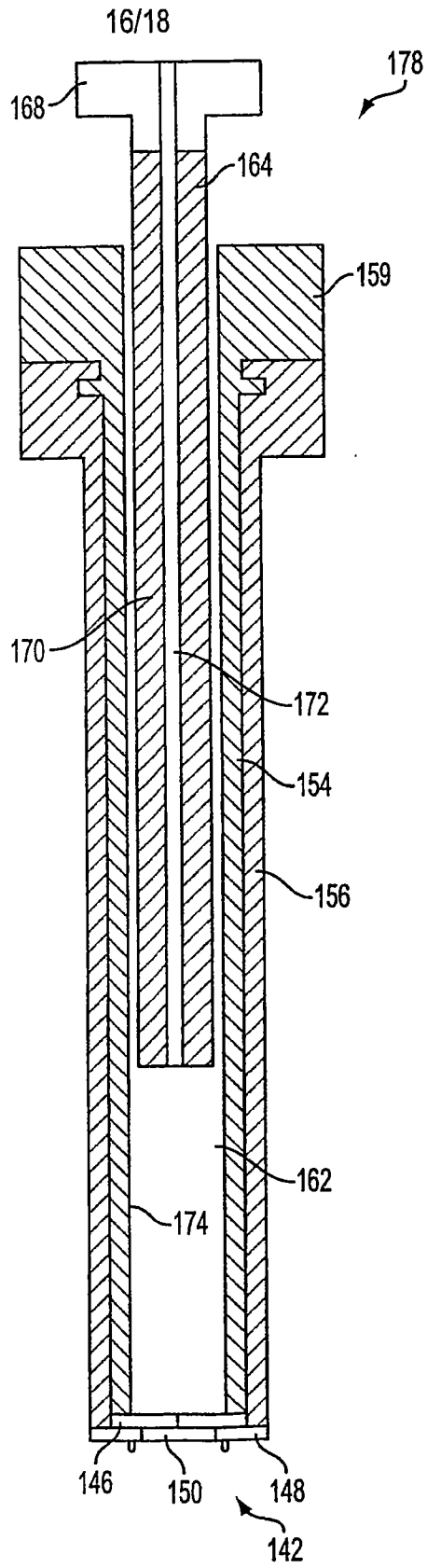

FIG. 10B

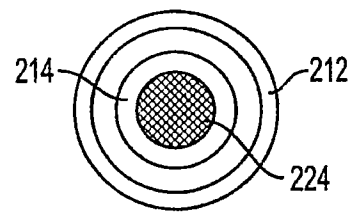
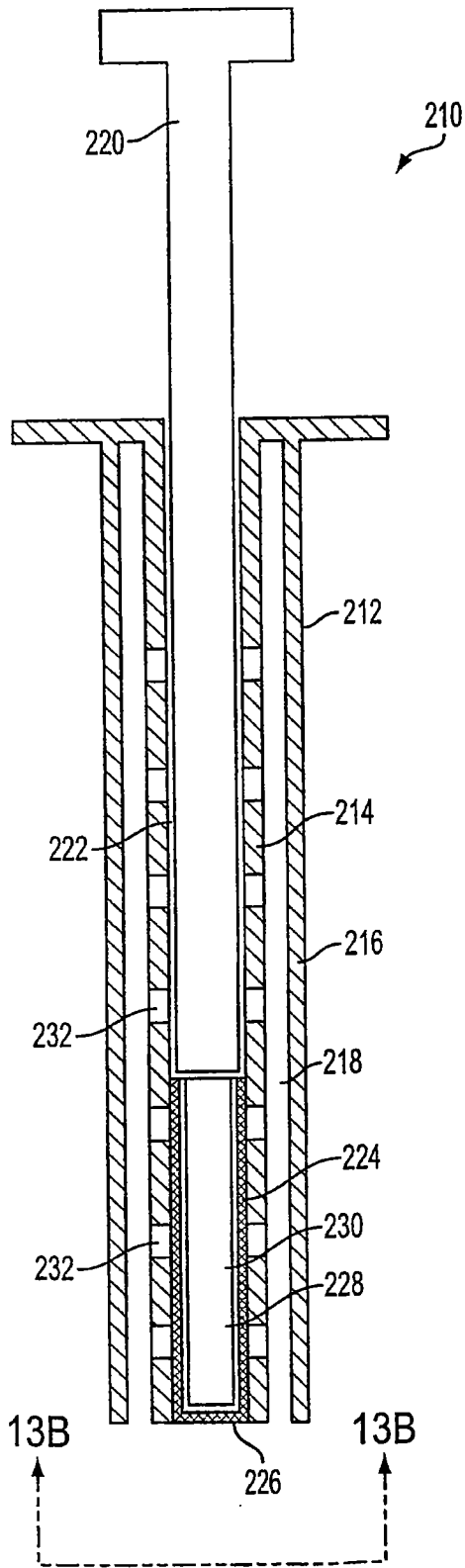

FIG. 13B

FIG. 13A

(19) World Intellectual Property Organization  
International Bureau



(43) International Publication Date  
12 February 2004 (12.02.2004)

PCT

(10) International Publication Number  
WO 2004/012602 A3

- (51) International Patent Classification<sup>7</sup>: A61B 17/00
- (21) International Application Number: PCT/EP2003/008246
- (22) International Filing Date: 25 July 2003 (25.07.2003)
- (25) Filing Language: English
- (26) Publication Language: English
- (30) Priority Data: 60/401,226 1 August 2002 (01.08.2002) US
- (71) Applicant (for all designated States except US): ABBOTT LABORATORIES VASCULAR ENTERPRISES, LIMITED [IE/IE]; Earlsfort Center, Terrace, Dublin 2 (IE).
- (72) Inventor; and
- (75) Inventor/Applicant (for US only): MICHLITSCH, Kenneth, J. [US/US]; 4613 Pamela Commons, Livermore, CA 94550 (US).
- (74) Agent: VOSSIUS & PARTNER; Siebertstrasse 4, 81675, Munich (DE).
- (81) Designated States (national): AE, AG, AL, AM, AT, AU, AZ, BA, BB, BG, BR, BY, BZ, CA, CH, CN, CO, CR, CU, CZ, DE, DK, DM, DZ, EC, EE, ES, FI, GB, GD, GE, GH, GM, HR, HU, ID, IL, IN, IS, JP, KE, KG, KP, KR, KZ, LC, LK, LR, LS, LT, LU, LV, MA, MD, MG, MK, MN, MW, MX, MZ, NI, NO, NZ, OM, PG, PH, PL, PT, RO, RU, SC, SD, SE, SG, SK, SL, SY, TJ, TM, TN, TR, TT, TZ, UA, UG, US, UZ, VC, VN, YU, ZA, ZM, ZW.
- (84) Designated States (regional): ARIPO patent (GH, GM, KE, LS, MW, MZ, SD, SL, SZ, TZ, UG, ZM, ZW), Eurasian patent (AM, AZ, BY, KG, KZ, MD, RU, TJ, TM), European patent (AT, BE, BG, CH, CY, CZ, DE, DK, EE, ES, FI, FR, GB, GR, HU, IE, IT, LU, MC, NL, PT, RO, SE, SI, SK, TR), OAPI patent (BF, BJ, CF, CG, CI, CM, GA, GN, GQ, GW, ML, MR, NE, SN, TD, TG).

[Continued on next page]

(54) Title: AUTOLOGOUS WOUND SEALING APPARATUS

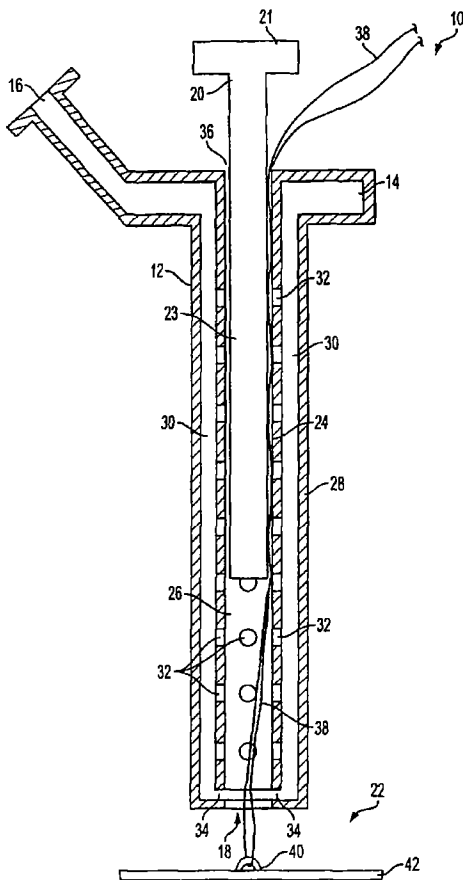

(57) Abstract: Apparatus (10) is provided for sealing a vascular puncture tract by forming the autologous plug within the puncture tract, and extruding that plug into the puncture tract. The apparatus of the present invention forms an autologous blood plug by drawing blood into the apparatus from a vessel, mixing a blood congealing agent with the drawn blood, and ejecting a plug formed from the clotted blood within the puncture tract. Also provided are various closure elements (22) to isolate the drawn blood from the vessel during mixture with the blood congealing agent, and to facilitate placement of the apparatus relative to the vessel.

WO 2004/012602 A3

INTERNATIONAL SEARCH REPORT

International Application No

PCT/EP 03/08246

A. CLASSIFICATION OF SUBJECT MATTER

IPC 7 A61B17/00

According to International Patent Classification (IPC) or to both national classification and IPC

B. FIELDS SEARCHED

Minimum documentation searched (classification system followed by classification symbols)

IPC 7 A61B A61L

Documentation searched other than minimum documentation to the extent that such documents are included in the fields searched

Electronic data base consulted during the international search (name of data base and, where practical, search terms used)

EPO-Internal, WPI Data, PAJ

C. DOCUMENTS CONSIDERED TO BE RELEVANT

Category *	Citation of document, with indication, where appropriate, of the relevant passages	Relevant to claim No.
X	EP 1 159 982 A (NOVOSTE CORP) 5 December 2001 (2001-12-05)  column 8, paragraph 2 -column 11, paragraph 3 figures 13-15	1,2,4, 11-13, 16-20
X	US 5 545 178 A (KENSEY KENNETH ET AL) 13 August 1996 (1996-08-13) column 8, paragraph 2 -column 10, paragraph 5 figures 1,2	1-6,11, 12,17-20
X	US 5 649 959 A (HANNAM PETER HENRY ET AL) 22 July 1997 (1997-07-22) column 12, line 66 -column 13, line 43 figures 10-12	1,2,4-6, 13,16,19
	-/--	

Further documents are listed in the continuation of box C.

Patent family members are listed in annex.

\* Special categories of cited documents:

- \*A\* document defining the general state of the art which is not considered to be of particular relevance
- \*E\* earlier document but published on or after the international filing date
- \*L\* document which may throw doubts on priority claim(s) or which is cited to establish the publication date of another citation or other special reason (as specified)
- \*O\* document referring to an oral disclosure, use, exhibition or other means
- \*P\* document published prior to the international filing date but later than the priority date claimed

- \*T\* later document published after the international filing date or priority date and not in conflict with the application but cited to understand the principle or theory underlying the invention
- \*X\* document of particular relevance; the claimed invention cannot be considered novel or cannot be considered to involve an inventive step when the document is taken alone
- \*Y\* document of particular relevance; the claimed invention cannot be considered to involve an inventive step when the document is combined with one or more other such documents, such combination being obvious to a person skilled in the art.
- \*&\* document member of the same patent family

Date of the actual completion of the international search

18 December 2003

Date of mailing of the international search report

12/01/2004

Name and mailing address of the ISA

European Patent Office, P.B. 5818 Patentlaan 2  
NL - 2280 HV Rijswijk  
Tel. (+31-70) 340-2040, Tx. 31 651 epo nl,  
Fax: (+31-70) 340-3016

Authorized officer

Schießl, W

# INTERNATIONAL SEARCH REPORT

Information on patent family members

International Application No

PCT/EP 03/08246

Patent document cited in search report	Publication date	Patent family member(s)	Publication date	
EP 1159982	A	05-12-2001	US 5419765 A	30-05-1995
			EP 1159982 A1	05-12-2001
			EP 1208869 A2	29-05-2002
			CA 2126633 A1	17-08-1995
			DE 69431395 D1	24-10-2002
			DE 69431395 T2	31-07-2003
			DE 69433123 D1	09-10-2003
			EP 0668086 A1	23-08-1995
			ES 2183821 T3	01-04-2003
			JP 7227423 A	29-08-1995
US 5545178	A	13-08-1996	US 5531759 A	02-07-1996
			AU 2462095 A	29-11-1995
			CA 2188751 A1	09-11-1995
			EP 0759725 A1	05-03-1997
			JP 9512461 T	16-12-1997
			WO 9529635 A1	09-11-1995
US 5649959	A	22-07-1997	AU 4865696 A	27-08-1996
			BG 100948 A	30-05-1997
			BR 9605305 A	07-10-1997
			CA 2187545 A1	15-08-1996
			EP 0755226 A1	29-01-1997
			FI 964044 A	09-12-1996
			HU 9602978 A2	28-05-1997
			JP 9505233 T	27-05-1997
			KR 227079 B1	15-10-1999
			NO 964292 A	09-12-1996
			PL 316902 A1	17-02-1997
			WO 9624290 A1	15-08-1996
			US 2002072767	A1
CA 2417962 A1	07-02-2002			
CN 1461204 T	10-12-2003			
EP 1307141 A2	07-05-2003			
WO 0209591 A2	07-02-2002			